

# DCA-25SSIU — SPECIFICATIONS

Table 5. Specifications		
Generator Specifications		
Model	DCA-25SSIU	
Type	Revolving field, self ventilated, open protected type synchronous	
Armature Connection	<b>Star with Neutral</b>	<b>Zig Zag</b>
Phase	3	Single
Standby Output	26.5 KVA (21.2 KW)	15.3KW
Prime Output	25 KVA (20 KW)	14.4KW
Voltage	240V or 480V	240/120V
Frequency	60 Hz	
Speed	1800 rpm	
Power Factor	0.8	1
Aux. AC Power	Single Phase, 60 Hz	
Voltage	120 V	
Output	4.8 KW (2.4 KW x 2)	
Engine Specifications		
Model	Isuzu QD-6(C240)	
Type	4 Cycle, water-cooled, swirl combustion chamber	
No. of Cylinders	4 cylinders	
Bore x Stroke	3.38 in. x 4 in. (86 mm x 102 mm)	
Rated Output	30.6HP/1800 rpm	
Displacement	144 cu. in. (2369cc)	
Starting	Electric	
Coolant Capacity	2.9 gal. (11 liters)	
Lube Oil Capacity	1.45 gal. (5.5 liters)	
Fuel Consumption	1.65 gal. (6.3L)/hr at <b>full load</b>	1.3 gal. (5.0L)/hr at <b>3/4 load</b>
	0.9 gal. (3.4L)/hr at <b>1/2 load</b>	0.6 gal. (2.3L)/hr at <b>1/4 load</b>
Battery	12V- 70AH	
Fuel	#2 Diesel Fuel	

# DCA-25SSIU — GENERATOR WIRING DIAGRAM

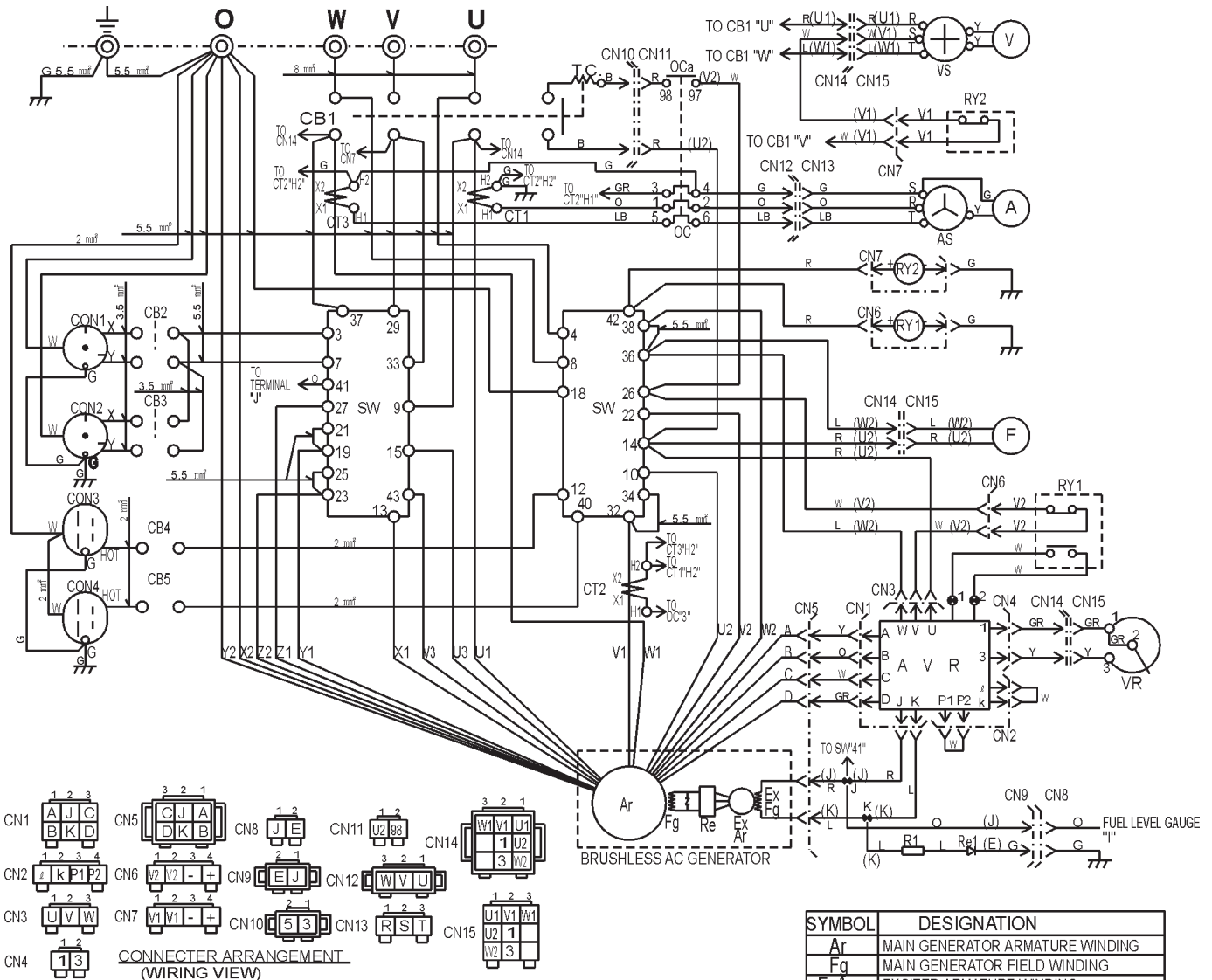

COLOR CODE			
WIRE COLOR	WIRE COLOR	WIRE COLOR	WIRE COLOR
B	BLACK	R	RED
L	BLUE	W	WHITE
BR	BROWN	Y	YELLOW
G	GREEN	LB	LIGHT BLUE
GR	GRAY	LG	LIGHT GREEN
V	VIOLET	O	ORANGE
P	PINK		

Notice  
1. No designation lead size : 1.25mm<sup>2</sup>

SYMBOL	DESIGNATION
Ar	MAIN GENERATOR ARMATURE WINDING
Fg	MAIN GENERATOR FIELD WINDING
ExAr	EXCITER ARMATURE WINDING
ExFg	EXCITER FIELD WINDING
Re	RECTIFIER
AVR	AUTOMATIC VOLTAGE REGULATOR
VR	VOLTAGE REGULATOR (RHEOSTAT)
CT 1,2,3	CURRENT TRANSFORMER
AS	CHANGE-OVER SWITCH, AMMETER
A	AC, AMMETER
VS	CHANGE-OVER SWITCH, VOLTMETER
V	AC, VOLTMETER
F	FREQUENCY METER
CB1	CIRCUIT BREAKER
CB2,3	CIRCUIT BREAKER
CB4,5	CIRCUIT BREAKER
CN1,2	RECEPTACLE
CN3,4	RECEPTACLE
OC	OVER CURRENT RELAY
SW	SELECTOR SWITCH
RY1,2	RELAY UNIT
R1	RESISTOR
Re1	RECTIFIER
•J,K	TERMINAL

# DCA-25SSIU — ENGINE WIRING DIAGRAM

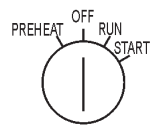
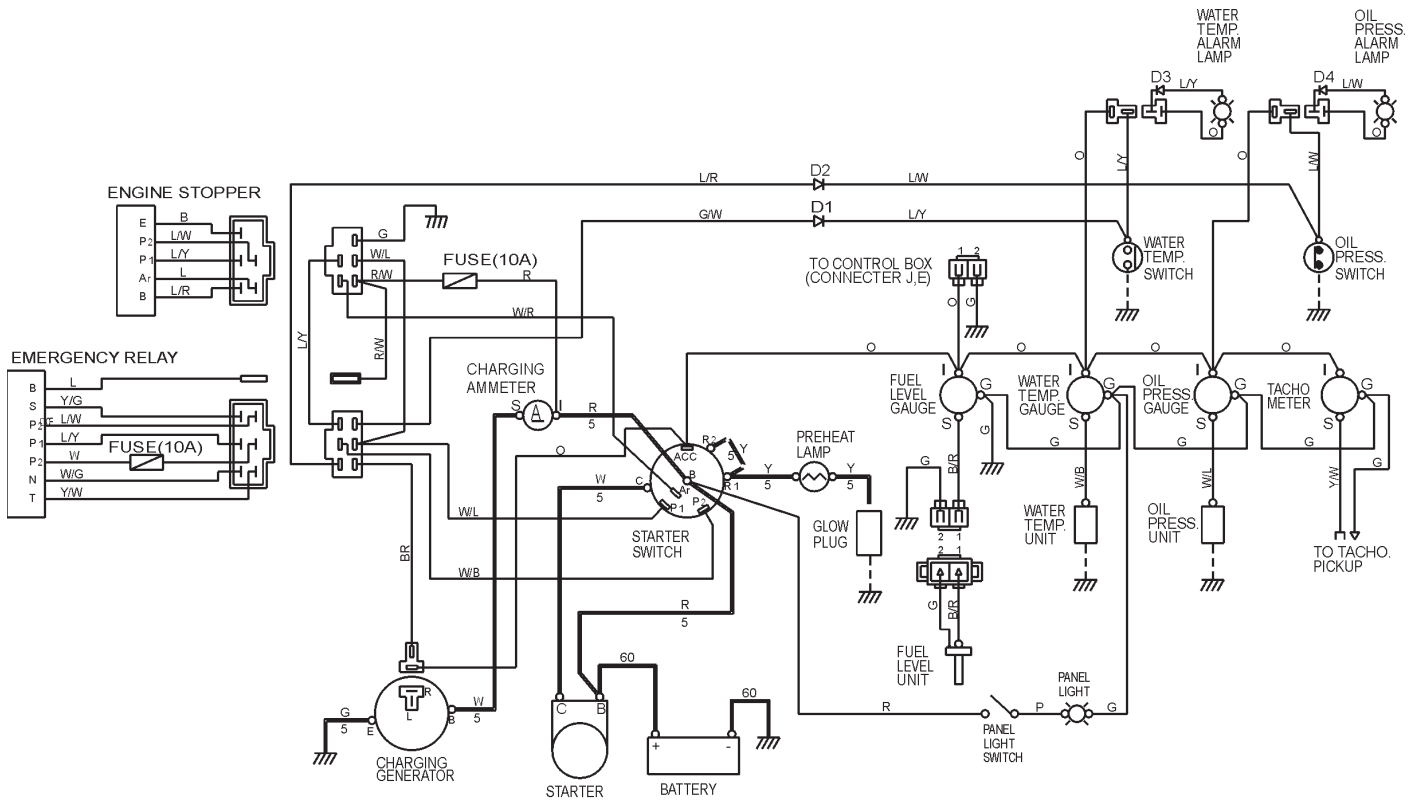

	KEY CONNECTION DIAGRAM							
	B	R 1	ACC	R 2	C	Ar	P 1	P 2
OFF	○					○	○	
PREHEAT	○	○				○	○	
RUN	○		○			○	○	
START	○			○	○	○	○	○

CONNECTOR: view from inserting wire side

WIRE SIZE	COLOR CODE	
60: 60 mm <sup>2</sup>	WIRE COLOR	WIRE COLOR
5: 5 mm <sup>2</sup>	B BLACK	R RED
No: 1.25 mm <sup>2</sup>	L BLUE	W WHITE
	BR BROWN	Y YELLOW
	G GREEN	LB LIGHT BLUE
	GR GRAY	LG LIGHT GREEN
	V VIOLET	O ORANGE
	P PINK	WIRE COLOR LINE COLOR